









Pegasus
hydraulics

Valves



13



	Product Groups	Page
	General information	13.02–13.04
	2-way high pressure lever operated ball valves	
	General information and pressure ratings	13.05–13.06
	Part codes and dimensions	13.07–13.08
	3-way high pressure lever operated ball valves	
	General information and pressure ratings	13.09–13.11
	Part codes and dimensions	13.12–13.14
	2-way high pressure lever operated SAE flanged ball valve	13.15
	2-way low pressure lever operated ball valve	13.16
	3-way low pressure lever operated ball valves	
	L bore	13.17
	T bore	13.18
	High pressure shut off valves	
	Externally threaded spindle	13.19
	Internally threaded spindle	13.20
	Needle valves	
	BSP parallel and NPT female	13.21
	Pressure drop data	13.22

1. General information

Ball valves are utilised to shut-off pressurised media in systems which incorporate rigid tubes or hoses.

When designing a system, the medium, pressure, temperature and other factors will influence which ball valves are selected, in terms of the materials of the body of the valve, the seals and the seats. Using media which are unsuitable for the materials and performance of the valve will reduce its operating lifespan. It is always important to adhere to the pressure and temperature limitations of the selected valve (ball valve bodies are often marked with these performance parameters).

When designing a system, it is also important to take into account any peaks or impulses in the pressure which the valve is intended to handle. These valves are designed to operate in line with the pressure rating of the other components of the system, such as fittings, flanges and tube / pipe.

Ball valves are opened and closed by means of a 1/4 turn of the handle. In accordance with EN ISO 5211.8, the handle must be turned clockwise to close the valve. The notch in the face of the spindle plate indicates the current position of the ball.

Ball valves can be manually operated, or may be actuated. Please inform us as to the method of intended operation when ordering.

When attaching valve control accessories such as actuators or limit switches, please refer to the operating instructions provided by the accessory manufacturer.

In relation to ATEX, the valves are considered as non-electrical equipment and therefore according to EC directive 94/9/EG are not considered an ignition source.

2. Fitting guidelines

Before installation, it is important to check that the valve is free from transit damage and is suitable for its intended application. Never install a damaged valve. All tubes and flexible hoses should be flushed before connecting to the valves to ensure contaminants cannot damage the seals and the seats of the valve, which may cause leaks and malfunction. The system must be de-pressurised and installation must only be undertaken by a qualified operator.

All rigid tubes must be free of tension when connecting to the valve. Additionally, when connecting to the valve it is essential that a spanner

is attached to the valve end adapter to prevent the valve from disassembling whilst the connection is made. Any disassembly of the valve invalidates the warranty. After the valve has been installed, the system should be tested for correct operation.

When dealing with poisonous, explosive or otherwise dangerous media, it is essential to completely drain the system to prevent injury, PPE should be worn at all times.

Flanged ball valves require that the connecting flange must be centred with the bolts of the flanges before tightening. If necessary, the assembled valve must be hoisted into place, assembled. Always use a new, undamaged, intermediary flange seal as per the connection standards. Appropriately rated bolts and nuts must be used and always check the length of the required flange bolts.

With regard to valves with welded connections, it is important that no welding residue finds itself within the inner workings of the valve and that during welding that the temperature of the valve does not increase to the point that the internal sealing materials are damaged.

Once again, never exceed the published performance data for any valve.

3. Initial operation

Before initial operation, it is important that all instructions have been read and implemented.

Installation and initial operation (commissioning) should only be undertaken by qualified personnel.

If a valve has been stored for some time, or if a valve has been fixed in one position for some time, it may require more torque than normal to operate.

Any newly commissioned system must be bled to remove any gas bubbles which could cause an explosion if the system is abruptly pressurised. Therefore, incremental increases in pressure are recommended.

When ball valves are used as pipeline ends, the open end must be closed correctly, because any incorrectly tightened components could cause injury or death.

4. Maintenance and surveying

When de-pressurising and draining a system, in order to prevent it from frost damage or for cleaning, the internals of the valve should be drained by moving the handle to the 45° position. The ball valve must not be detached from the system. Sealants should

never be used. All ball valves should be inspected at regular intervals to check for leaks, function and damage. If a valve is in a heavy duty application, it should be inspected more regularly.

Ball valves which are installed for long periods without being operated should be turned at least every six months to preserve its functionality.

After inspection, if a valve is found to be dysfunctional, ie leaks, frozen in position, corroded etc. it should be replaced immediately.

5. Removal instructions

Removal of any valve should be conducted by qualified personnel only and only once the system (and valve by moving the handle to the 45° position) has been depressurised.

When dealing with harmful media, it is important to completely drain the system whilst wearing appropriate PPE.

6. Warning

Secure adapter during installation



Don't dismantle



No welding, drilling, etc.



Don't operate a ball valve with a tool or an extension

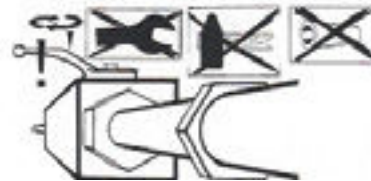

Don't remove under pressure



Risk of injury from media residue.

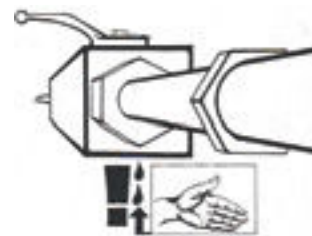

Please adhere to the guidance provided in this general information, as the valve manufacturers assume no liability when these guidelines are not followed. The ball valves are only to be used for the applications described by the manufacturer.

Damaged caused as a result of incorrect installation, or handling by unqualified personnel is not covered under the manufacturer's warranty.

The operating range of the ball valves is strictly between its end stops. The valves must be operated in either fully open or fully closed positions only.

Ball valves are not approved for controlling or throttling flow. Operating the valve in an intermediate position can cause damage to the valve seats, which in turn, leads to leaks or spindles that will no longer turn. Additionally, flow reduction leads to a considerable rise in temperature on the surface of the valve.

Do not use tools (eg. extension bars, spanners, wrenches, hammers) to operate the valve. Using any of these such tools can damage the spindle and the body.

Any special applications or operating environments, such as humidity, vibration, operating frequency, electromagnetic fields, explosive zones, antistatic etc, should be considered and mentioned when ordering.

The ball valves must be used for compatible media only. Semifluid or hardening media must never be used.

Avoid medium contamination. Contaminated media leads to damage of the valve components, thereby leading to valve failure.

Temperature limits must be adhered to, otherwise the valve may fail prematurely. Valves must be stored as supplied in a dry, contamination-free environment away from direct sunlight. Only remove the protective caps just before installation.

When installing a valve in an explosive zone, limit the operating frequency to 10/min to prevent the valve frictions from self-warming.

Subjecting the valve to excessive pressures and temperatures beyond its published operating parameters will lead to failure of the valve. In this event, injury up to and including death may occur.

Any user modification of the valve design, especially the drilling of mounting holes or the attachment of welded plates invalidates any warranty and is therefore not advised in any way.

In the event a valve fails, the valve must be replaced immediately by a qualified professional after the system has been depressurised. If necessary, the entire system must be shut down.

Any valve repairs should only be performed by the manufacturer. Any disassembly / stripping / servicing of the valve invalidates any manufacturer guarantee.

Please refer to local legislation regarding accident prevention, safety regulations in the geographical area of installation.

Before any maintenance is performed on the valves, the following should be actioned :

Disconnect actuator power supply.

Exclude the possibility of 3rd party accidental system start-up.

Depressurise and drain the system.

Be cautious of any potentially harmful medium residue and wear PPE.

Where applicable, allow the system to cool.

Never exceed the product parameters of pressure, temperature and media.

Warning !

Incorrect product selection or usage of any product featured in this catalogue, or failure to follow published safety instructions invalidates any warranty and more importantly, may result in serious injury, including death.

The information provided by Pegasus Hydraulics Ltd is to be used as a guide for professionally qualified installers only. Ultimately, it is the responsibility of the customer to assess all of the factors before ordering a product. All aspects of the product, its performance, its limitations, the environment, the medium, the safety requirements, the service requirements etc should be assessed before making a selection.

The products described herein, including without limitation, product features, specifications, designs, availability and pricing are subject to change by Pegasus Hydraulics Ltd at any time without notice.

RKH ball valves

DN 4 to DN 50

The body, end connections, ball and stem are material 1.4571 – AISI 316Ti stainless steel.

Each ball valve is subjected to an inspection before despatch.

Inspection control certificates 3.1 B or 3.1 C per DIN EN 10204 can be supplied on request against invoice.

Other materials as 254Smo or Hastelloy, etc. on request.

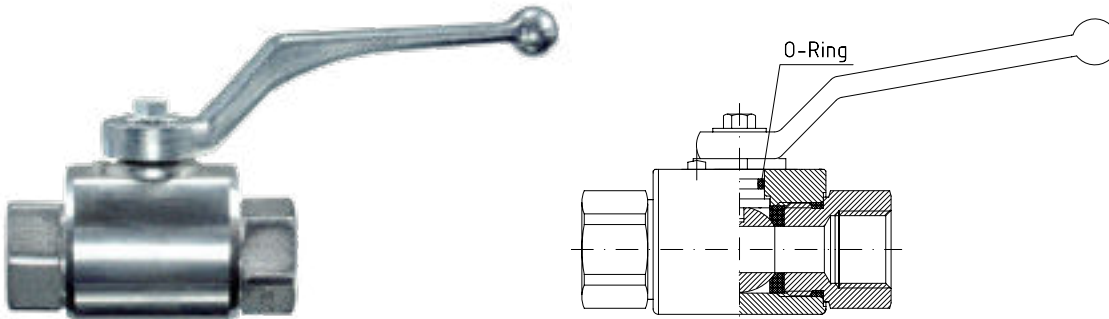

2-way high pressure lever operated ball valve

BOOK INDEX

SECTION INDEX

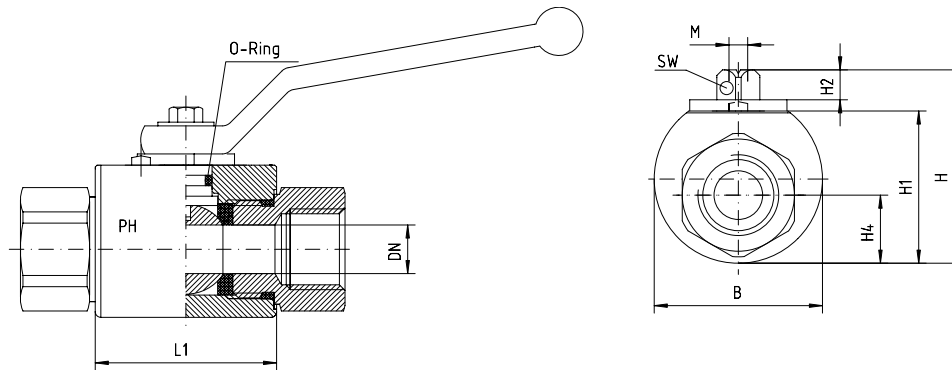

DN mm	PB bar	L1 mm	B mm	H mm	H1 mm	H2 mm	H4 mm	M mm	SW \varnothing mm
5	500	36	35	43.5	32	8.0	13.0	M 5	9
6	500	36	35	43.5	32	8.0	13.0	M 5	9
8	500	36	35	43.5	32	8.0	13.0	M 5	9
10	500	43	42	49.5	38	8.0	16.5	M 5	9
13	500	48	45	51.5	40	8.0	17.5	M 5	9
16	400	48	50	62.0	46	12.0	19.0	M 6	12
20	400	62	60	73.0	57	12.0	24.5	M 6	14
24	400	66	65	79.0	63	12.0	28.0	M 6	14
32	350	81	90	104.0	84	13.5	38.0	M 8	17
38	350	86	100	112.0	93	13.5	42.5	M 8	17
48	350	101	120	131.0	111	13.5	50.0	M 8	17

The indicated working pressure PB is only valid for the standard version 4423.
Body dimensions are for all the combinations.

2-way high pressure lever operated ball valve

BOOK INDEX

SECTION INDEX

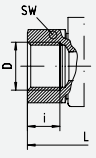
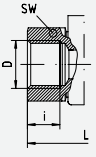
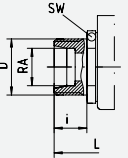
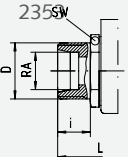
Body Ball Stem Ball Sealing Stem Sealing		1.4571 (AISI 316Ti) 1.4571 (AISI 316Ti) 1.4571 (AISI 316Ti) PTFE (to 100 bar) FKM		1.4571 (AISI 316Ti) 1.4571 (AISI 316Ti) 1.4571 (AISI 316Ti) PTFE (to 100 bar) EPDM		1.4571 (AISI 316Ti) 1.4571 (AISI 316Ti) 1.4571 (AISI 316Ti) POM NBR	
				Corrosive Media	Water and Steam	Hydraulics - Standard Version	
				-20°C to 100°C	-20°C to 140°C	-20°C to 100°C	
Connection		Part code		Part code		Part code	
DN		D	RA				
01 BSP Female Thread DIN ISO 228 	5	G 1/8"		RKH-G 1/8"-4445	RKH-G 1/8"-4446	RKH-G 1/8"-4423	
	6	G 1/4"		RKH-G 1/4"-4445	RKH-G 1/4"-4446	RKH-G 1/4"-4423	
	10	G 3/8"		RKH-G 3/8"-4445	RKH-G 3/8"-4446	RKH-G 3/8"-4423	
	13	G 1/2"		RKH-G 1/2"-4445	RKH-G 1/2"-4446	RKH-G 1/2"-4423	
	16	G 5/8"		RKH-G 5/8"-4445	RKH-G 5/8"-4446	RKH-G 5/8"-4423	
	20	G 3/4"		RKH-G 3/4"-4445	RKH-G 3/4"-4446	RKH-G 3/4"-4423	
	24	G 1"		RKH-G 1"-4445	RKH-G 1"-4446	RKH-G 1"-4423	
	32	G 1 1/4"		RKH-G 1 1/4"-4445	RKH-G 1 1/4"-4446	RKH-G 1 1/4"-4423	
	38	G 1 1/2"		RKH-G 1 1/2"-4445	RKH-G 1 1/2"-4446	RKH-G 1 1/2"-4423	
48	G 2"		RKH-G 2"-4445	RKH-G 2"-4446	RKH-G 2"-4423		
02 NPT Female Thread ANSI B 2.1 	5	1/8"-27 NPT		RKH-1/8"-NPT-4445	RKH-1/8"-NPT-4446	RKH-1/8"-NPT-4423	
	6	1/4"-18 NPT		RKH-1/4"-NPT-4445	RKH-1/4"-NPT-4446	RKH-1/4"-NPT-4423	
	10	3/8"-18 NPT		RKH-3/8"-NPT-4445	RKH-3/8"-NPT-4446	RKH-3/8"-NPT-4423	
	13	1/2"-14 NPT		RKH-1/2"-NPT-4445	RKH-1/2"-NPT-4446	RKH-1/2"-NPT-4423	
	20	3/4"-14 NPT		RKH-3/4"-NPT-4445	RKH-3/4"-NPT-4446	RKH-3/4"-NPT-4423	
	24	1"-11.5 NPT		RKH-1"-NPT-4445	RKH-1"-NPT-4446	RKH-1"-NPT-4423	
	32	1 1/4"-11.5 NPT		RKH-1 1/4"-NPT-4445	RKH-1 1/4"-NPT-4446	RKH-1 1/4"-NPT-4423	
	38	1 1/2"-11.5 NPT		RKH-1 1/2"-NPT-4445	RKH-1 1/2"-NPT-4446	RKH-1 1/2"-NPT-4423	
48	2"-11.5 NPT		RKH-2"-NPT-4445	RKH-2"-NPT-4446	RKH-2"-NPT-4423		
03 Compression connection Light Series DIN 2353 	5	M 12 x 1.5	6	RKH-06-L-4445	RKH-06-L-4446	RKH-06-L-4423	
	6	M 14 x 1.5	8	RKH-08-L-4445	RKH-08-L-4446	RKH-08-L-4423	
	8	M 16 x 1.5	10	RKH-10-L-4445	RKH-10-L-4446	RKH-10-L-4423	
	10	M 18 x 1.5	12	RKH-12-L-4445	RKH-12-L-4446	RKH-12-L-4423	
	13	M 22 x 1.5	15	RKH-15-L-4445	RKH-15-L-4446	RKH-15-L-4423	
	13	M 26 x 1.5	18	RKH-18-L-4445	RKH-18-L-4446	RKH-18-L-4423	
	20	M 30 x 2	22	RKH-22-L-4445	RKH-22-L-4446	RKH-22-L-4423	
	24	M 36 x 2	28	RKH-28-L-4445	RKH-28-L-4446	RKH-28-L-4423	
	32	M 45 x 2	35	RKH-35-L-4445	RKH-35-L-4446	RKH-35-L-4423	
	38	M 52 x 2	42	RKH-42-L-4445	RKH-42-L-4446	RKH-42-L-4423	
04 Compression connection Heavy Series DIN 2353 	5	M 14 x 1.5	6	RKH-06-S-4445	RKH-06-S-4446	RKH-06-S-4423	
	5	M 16 x 1.5	8	RKH-08-S-4445	RKH-08-S-4446	RKH-08-S-4423	
	6	M 18 x 1.5	10	RKH-10-S-4445	RKH-10-S-4446	RKH-10-S-4423	
	8	M 20 x 1.5	12	RKH-12-S-4445	RKH-12-S-4446	RKH-12-S-4423	
	10	M 22 x 1.5	14	RKH-14-S-4445	RKH-14-S-4446	RKH-14-S-4423	
	13	M 24 x 1.5	16	RKH-16-S-4445	RKH-16-S-4446	RKH-16-S-4423	
	13	M 30 x 2	20	RKH-20-S-4445	RKH-20-S-4446	RKH-20-S-4423	
	20	M 36 x 2	25	RKH-25-S-4445	RKH-25-S-4446	RKH-25-S-4423	
	24	M 42 x 2	30	RKH-30-S-4445	RKH-30-S-4446	RKH-30-S-4423	
	32	M 52 x 2	38	RKH-38-S-4445	RKH-38-S-4446	RKH-38-S-4423	

Dimensions are subject to change.

2-way high pressure lever operated ball valve

BOOK INDEX

SECTION INDEX

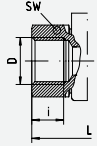
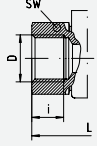
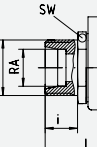
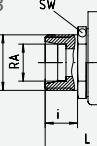
Connection	Weight kg						
	DN	D	RA	L	i	SW	
01 BSP Female Thread DIN ISO 228 	5	G 1/8"		69	9	22	0.35
	6	G 1/4"		69	12	22	0.35
	10	G 3/8"		73	12	27	0.5
	13	G 1/2"		85	14	30	0.65
	16	G 5/8"		84	14	32	0.75
	20	G 3/4"		96	17	41	1.5
	24	G 1"		113	19	46	1.8
	32	G 1 1/4"		110	20	60	3.8
	38	G 1 1/2"		120	22	70	6.1
	48	G 2"		140	28	85	9.1
02 NPT Female Thread ANSI B 2.1 	5	1/8" -27 NPT		69	12	22	0.35
	6	1/4" -18 NPT		69	17	22	0.35
	10	3/8" -18 NPT		73	17	27	0.5
	13	1/2" -14 NPT		92	22	30	0.65
	20	3/4" -14 NPT		97	23	41	1.5
	24	1" -11.5 NPT		113	27	46	1.8
	32	1 1/4" -11.5 NPT		115	28	60	3.8
	38	1 1/2" -11.5 NPT		135	28	70	6.1
	48	2" -11.5 NPT		140	30	85	9.1
03 Compression connection Light Series DIN 2353 	5	M 12 x 1.5	6	67	10	22	0.3
	6	M 14 x 1.5	8	67	10	22	0.3
	8	M 16 x 1.5	10	71	11	22	0.3
	10	M 18 x 1.5	12	75	11	27	0.5
	13	M 22 x 1.5	15	84	12	30	0.6
	13	M 26 x 1.5	18	84	12	30	0.6
	20	M 30 x 2	22	102	14	41	1.5
	24	M 36 x 2	28	108	14	46	1.8
	32	M 45 x 2	35	128	16	60	3.6
	38	M 52 x 2	42	133	16	70	5.9
04 Compression connection Heavy Series DIN 2353 	5	M 14 x 1.5	6	73	12	22	0.3
	5	M 16 x 1.5	8	73	12	22	0.35
	6	M 18 x 1.5	10	73	12	22	0.35
	8	M 20 x 1.5	12	76	12	22	0.35
	10	M 22 x 1.5	14	84	14	27	0.5
	13	M 24 x 1.5	16	87	14	30	0.6
	13	M 30 x 2	20	91	16	30	0.65
	20	M 36 x 2	25	110	18	41	1.5
	24	M 42 x 2	30	120	20	46	1.9
	32	M 52 x 2	38	140	22	60	3.7

2-way high pressure lever operated ball valve

BOOK INDEX

SECTION INDEX

Body, Connecting Parts, Ball and Stem Stainless Steel, 1.4571 (AISI 316Ti)

Each ball valve is subject to an inspection for resistance, sealing and special characteristics.

Inspection control certificates 3.1 per EN 10204 can be supplied on request against invoice.

Ball Sealing: POM

Stem Sealing: NBR

Hydraulics – Standard version

-20°C to 100°C

Measurements subject to alteration.

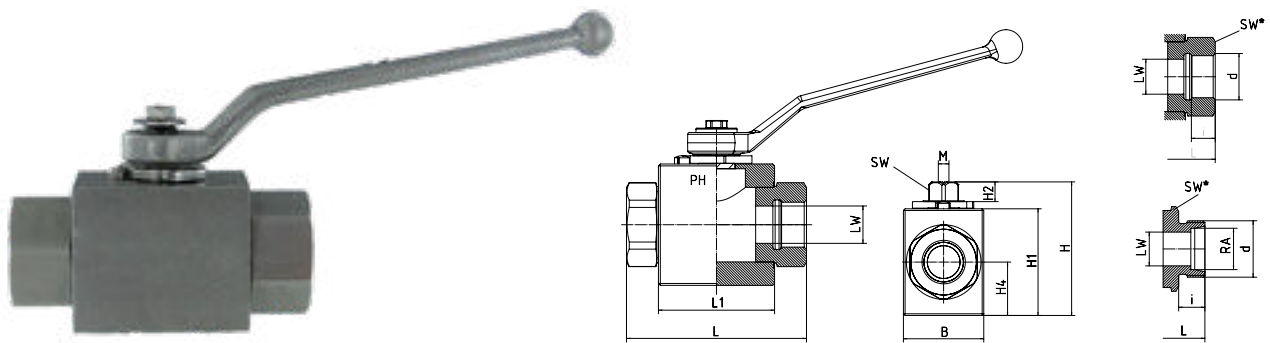

3-way high pressure lever operated ball valve

BOOK INDEX

SECTION INDEX

Available with L or T bore.

BK3 ball valves

DN 4 to DN 50

The body, end connections, ball and stem are material 1.4571 (AISI 316Ti).

Each ball valve is subjected to an inspection before despatch.

Inspection control certificates 3.1 B or 3.1 C per DIN EN 10204 can be supplied on request against invoice.

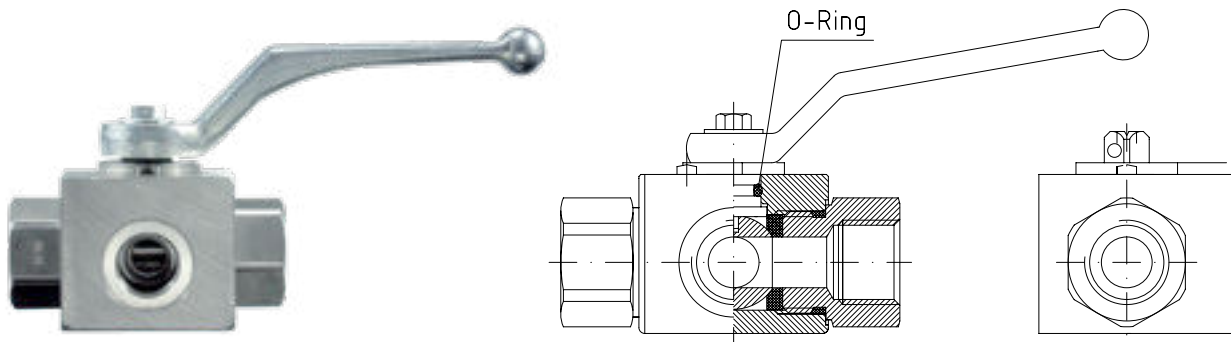

3-way high pressure lever operated ball valve

BOOK INDEX

SECTION INDEX

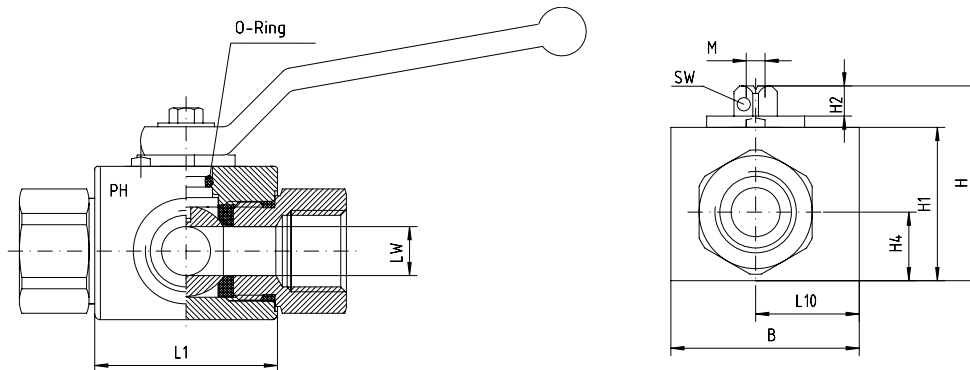

DN mm	PB1 bar	L1 mm	B mm	H mm	H1 mm	H2 mm	H4 mm	M mm	SW ϕ mm
4	400	35	40	46.5	35	8.0	16.0	M 5	9
6	400	35	40	46.5	35	8.0	16.0	M 5	9
8	400	35	40	46.5	35	8.0	16.0	M 5	9
10	400	42	45	51.5	40	8.0	18.0	M 5	9
13	400	47	50	56.0	40	8.0	17.0	M 5	9
20	320	61	65	73.5	57	12.0	24.5	M 6	14
25	350	63	80	81.5	65	12.0	30.0	M 6	14
32	350	78	100	99.0	80	13.5	38.0	M 8	17
40	250	85	105	109.0	90	13.5	42.0	M 8	17
50	250	100	120	139.0	120	13.5	62.0	M 8	17



The indicated working pressure PB is only valid for the standard version 4423.

Body dimensions are for all the combinations.

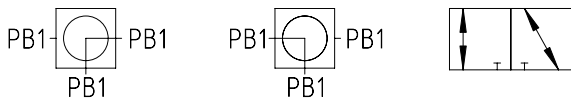

Type LA: L-bore 0° - 90° pressured from all ports possible

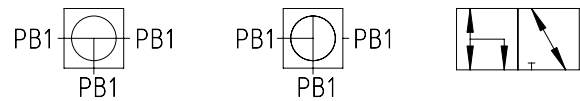

Type TA: T-bore 0° - 90° pressured from all ports possible

3-way high pressure lever operated ball valve

BOOK INDEX

SECTION INDEX

L-Bore

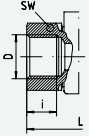
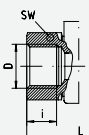
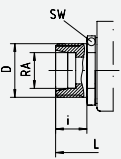
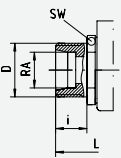
Connection	Body Ball Stem Ball Sealing Stem Sealing		V4a (AISI 316) V4a (AISI 316) V4a (AISI 316) PTFE (to 100 bar) FKM		V4a (AISI 316) V4a (AISI 316) V4a (AISI 316) POM NBR	
	DN	LW	D	RA	Corrosive Media -20°C to 100°C	Hydraulics - Standard Version -20°C to 100°C
01 BSP Female Thread DIN ISO 228 	4	5.0	G 1/8"		BK3-G 1/8"-4445-L	BK3-G 1/8"-4423-LA
	6	6.0	G 1/4"		BK3-G 1/4"-4445-L	BK3-G 1/4"-4423-LA
	10	9.0	G 3/8"		BK3-G 3/8"-4445-L	BK3-G 3/8"-4423-LA
	13	11.5	G 1/2"		BK3-G 1/2"-4445-L	BK3-G 1/2"-4423-LA
	20	18.0	G 3/4"		BK3-G 3/4"-4445-L	BK3-G 3/4"-4423-LA
	25	22.0	G 1"		BK3-G 1"-4445-L	BK3-G 1"-4423-LA
	32	30.0	G 1 1/4"		BK3-G 1 1/4"-4445-L	BK3-G 1 1/4"-4423-LA
	40	35.0	G 1 1/2"		BK3-G 1 1/2"-4445-L	BK3-G 1 1/2"-4423-LA
	50	44.0	G 2"		BK3-G 2"-4445-L	BK3-G 2"-4423-LA
02 NPT Female Thread ANSI B 2.1 	4	5.0	1/8"-27 NPT		BK3-1/8"-NPT-4445-L	BK3-1/8"-NPT-4423-LA
	6	6.0	1/4"-18 NPT		BK3-1/4"-NPT-4445-L	BK3-1/4"-NPT-4423-LA
	10	9.0	3/8"-18 NPT		BK3-3/8"-NPT-4445-L	BK3-3/8"-NPT-4423-LA
	13	11.5	1/2"-14 NPT		BK3-1/2"-NPT-4445-L	BK3-1/2"-NPT-4423-LA
	20	18.0	3/4"-14 NPT		BK3-3/4"-NPT-4445-L	BK3-3/4"-NPT-4423-LA
	25	22.0	1"-11.5 NPT		BK3-1"-NPT-4445-L	BK3-1"-NPT-4423-LA
	32	30.0	1 1/4"-11.5 NPT		BK3-1 1/4"-NPT-4445-L	BK3-1 1/4"-NPT-4423-LA
	40	35.0	1 1/2"-11.5 NPT		BK3-1 1/2"-NPT-4445-L	BK3-1 1/2"-NPT-4423-LA
	50	44.0	2"-11.5 NPT		BK3-2"-NPT-4445-L	BK3-2"-NPT-4423-LA
03 Compression connection Light Series DIN 2353 	4	5.0	M 12 x 1.5	6	BK3-6-L-4445-L	BK3-6-L-4423-LA
	6	6.0	M 14 x 1.5	8	BK3-8-L-4445-L	BK3-8-L-4423-LA
	8	7.0	M 16 x 1.5	10	BK3-10-L-4445-L	BK3-10-L-4423-LA
	10	9.0	M 18 x 1.5	12	BK3-12-L-4445-L	BK3-12-L-4423-LA
	13	11.5	M 22 x 1.5	15	BK3-15-L-4445-L	BK3-15-L-4423-LA
	13	11.5	M 26 x 1.5	18	BK3-18-L-4445-L	BK3-18-L-4423-LA
	20	18.0	M 30 x 2	22	BK3-22-L-4445-L	BK3-22-L-4423-LA
	25	18.0	M 36 x 2	28	BK3-28-L-4445-L	BK3-28-L-4423-LA
	32	30.0	M 45 x 2	35	BK3-35-L-4445-L	BK3-35-L-4423-LA
	40	35.0	M 52 x 2	42	BK3-42-L-4445-L	BK3-42-L-4423-LA
04 Compression connection Heavy Series DIN 2353 	4	5.0	M 14 x 1.5	6	BK3-6-S-4445-L	BK3-6-S-4423-LA
	4	5.0	M 16 x 1.5	8	BK3-8-S-4445-L	BK3-8-S-4423-LA
	6	6.0	M 18 x 1.5	10	BK3-10-S-4445-L	BK3-10-S-4423-LA
	8	7.0	M 20 x 1.5	12	BK3-12-S-4445-L	BK3-12-S-4423-LA
	10	9.0	M 22 x 1.5	14	BK3-14-S-4445-L	BK3-14-S-4423-LA
	13	11.5	M 24 x 1.5	16	BK3-16-S-4445-L	BK3-16-S-4423-LA
	13	11.5	M 30 x 2	20	BK3-20-S-4445-L	BK3-20-S-4423-LA
	20	18.0	M 36 x 2	25	BK3-25-S-4445-L	BK3-25-S-4423-LA
	25	22.0	M 42 x 2	30	BK3-30-S-4445-L	BK3-30-S-4423-LA
	32	30.0	M 52 x 2	38	BK3-38-S-4445-L	BK3-38-S-4423-LA

Dimensions are subject to change.

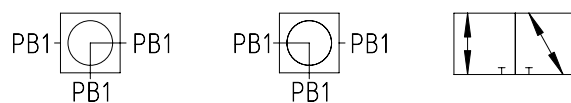

Type LA: L-bore 0° - 90° pressured from all ports possible

3-way high pressure lever operated ball valve

BOOK INDEX

SECTION INDEX

T-Bore

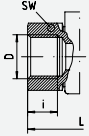
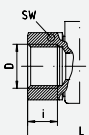
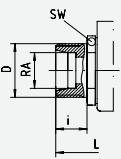
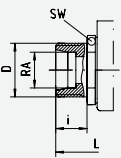
Body Ball Stem Ball Sealing Stem Sealing		V4a (AISI 316) V4a (AISI 316) V4a (AISI 316) PTFE (to 100 bar) FKM		V4a (AISI 316) V4a (AISI 316) V4a (AISI 316) POM NBR		
		Corrosive Media -20°C to 100°C		Hydraulics - Standard Version -20°C to 100°C		
Connection	DN	LW	D	RA	Part code	Part code
01 BSP Female Thread DIN ISO 228 	4	5.0	G 1/8"		BK3-G 1/8"-4445-T	BK3-G 1/8"-4423-TA
	6	6.0	G 1/4"		BK3-G 1/4"-4445-T	BK3-G 1/4"-4423-TA
	10	9.0	G 3/8"		BK3-G 3/8"-4445-T	BK3-G 3/8"-4423-TA
	13	11.5	G 1/2"		BK3-G 1/2"-4445-T	BK3-G 1/2"-4423-TA
	20	18.0	G 3/4"		BK3-G 3/4"-4445-T	BK3-G 3/4"-4423-TA
	25	22.0	G 1"		BK3-G 1"-4445-T	BK3-G 1"-4423-TA
	32	30.0	G 1 1/4"		BK3-G 1 1/4"-4445-T	BK3-G 1 1/4"-4423-TA
	40	35.0	G 1 1/2"		BK3-G 1 1/2"-4445-T	BK3-G 1 1/2"-4423-TA
02 NPT Female Thread ANSI B 2.1 	4	5.0	1/8"-27-NPT		BK3-1/8"-NPT-4445-T	BK3-1/8"-NPT-4423-TA
	6	6.0	1/4"-18 NPT		BK3-1/4"-NPT-4445-T	BK3-1/4"-NPT-4423-TA
	10	9.0	3/8"-18 NPT		BK3-3/8"-NPT-4445-T	BK3-3/8"-NPT-4423-TA
	13	11.5	1/2"-14 NPT		BK3-1/2"-NPT-4445-T	BK3-1/2"-NPT-4423-TA
	20	18.0	3/4"-14 NPT		BK3-3/4"-NPT-4445-T	BK3-3/4"-NPT-4423-TA
	25	22.0	1"-11.5 NPT		BK3-1"-NPT-4445-T	BK3-1"-NPT-4423-TA
	32	30.0	1 1/4"-11.5 NPT		BK3-1 1/4"-NPT-4445-T	BK3-1 1/4"-NPT-4423-TA
	40	35.0	1 1/2"-11.5 NPT		BK3-1 1/2"-NPT-4445-T	BK3-1 1/2"-NPT-4423-TA
03 Compression connection Light Series DIN 2353 	4	5.0	M 12 x 1.5	6	BK3-6-L-4445-T	BK3-6-L-4423-TA
	6	6.0	M 14 x 1.5	8	BK3-8-L-4445-T	BK3-8-L-4423-TA
	8	7.0	M 16 x 1.5	10	BK3-10-L-4445-T	BK3-10-L-4423-TA
	10	9.0	M 18 x 1.5	12	BK3-12-L-4445-T	BK3-12-L-4423-TA
	13	11.5	M 22 x 1.5	15	BK3-15-L-4445-T	BK3-15-L-4423-TA
	13	11.5	M 26 x 1.5	18	BK3-18-L-4445-T	BK3-18-L-4423-TA
	20	18.0	M 30 x 2	22	BK3-22-L-4445-T	BK3-22-L-4423-TA
	25	22.0	M 36 x 2	28	BK3-28-L-4445-T	BK3-28-L-4423-TA
04 Compression connection Heavy Series DIN 2353 	4	5.0	M 14 x 1.5	6	BK3-6-S-4445-T	BK3-6-S-4423-TA
	4	5.0	M 16 x 1.5	8	BK3-8-S-4445-T	BK3-8-S-4423-TA
	6	6.0	M 18 x 1.5	10	BK3-10-S-4445-T	BK3-10-S-4423-TA
	8	7.0	M 20 x 1.5	12	BK3-12-S-4445-T	BK3-12-S-4423-TA
	10	9.0	M 22 x 1.5	14	BK3-14-S-4445-T	BK3-14-S-4423-TA
	13	11.5	M 24 x 1.5	16	BK3-16-S-4445-T	BK3-16-S-4423-TA
	13	11.5	M 30 x 2	20	BK3-20-S-4445-T	BK3-20-S-4423-TA
	20	18.0	M 36 x 2	25	BK3-25-S-4445-T	BK3-25-S-4423-TA
25	22.0	M 42 x 2	30	BK3-30-S-4445-T	BK3-30-S-4423-TA	
32	30.0	M 52 x 2	38	BK3-38-S-4445-T	BK3-38-S-4423-TA	

Dimensions are subject to change.

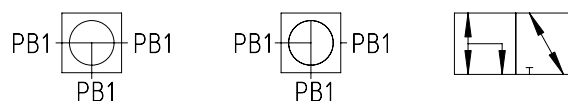

Type TA: T-bore 0° - 90° pressured from all ports possible

3-way high pressure lever operated ball valve

BOOK INDEX

SECTION INDEX

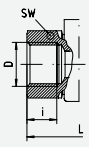
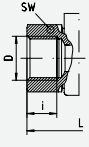
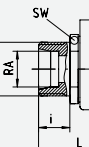
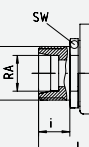
Connection	DN	LW	D	RA	Approx. Dimensions			
					L	L10	i	SW
01 BSP Female Thread DIN ISO 228 	4	5.0	G 1/8"		69	26.0	9	22
	6	6.0	G 1/4"		69	26.0	12	22
	10	9.0	G 3/8"		73	28.0	12	27
	13	11.5	G 1/2"		85	32.0	14	30
	20	18.0	G 3/4"		96	40.5	17	41
	25	22.0	G 1"		113	51.0	19	46
	32	30.0	G 1 1/4"		110	62.0	20	60
	40	35.0	G 1 1/2"		120	65.0	24	70
	50	44.0	G 2"		140	72.0	28	85
02 NPT Female Thread ANSI B 2.1 	4	5.0	1/8"-27 NPT		69	26.0	12	22
	6	6.0	1/4"-18 NPT		69	26.0	17	22
	10	9.0	3/8"-18 NPT		73	28.0	17	27
	13	11.5	1/2"-14 NPT		92	32.0	22	30
	20	18.0	3/4"-14 NPT		97	40.5	23	41
	25	22.0	1"-11.5 NPT		113	51.0	27	46
	32	30.0	1 1/4"-11.5 NPT		115	62.0	28	60
	40	35.0	1 1/2"-11.5 NPT		138	65.0	28	70
	50	44.0	2"-11.5 NPT		140	72.0	30	85
03* Compression connection Light Series DIN 2353 	4	5.0	M 12 x 1.5	6	67	41.5	10	22
	6	6.0	M 14 x 1.5	8	67	41.5	10	22
	8	7.0	M 16 x 1.5	10	71	41.5	11	22
	10	9.0	M 18 x 1.5	12	75	44.5	11	27
	13	11.5	M 22 x 1.5	15	84	50.0	12	30
	13	11.5	M 26 x 1.5	18	84	50.0	12	32
	20	18.0	M 30 x 2	22	102	60.5	14	41
	25	22.0	M 36 x 2	28	108	72.0	14	46
	32	30.0	M 45 x 2	35	128	86.0	16	60
04* Compression connection Heavy Series DIN 2353 	4	5.0	M 14 x 1.5	6				
	4	5.0	M 16 x 1.5	8	73	44.5	12	22
	6	6.0	M 18 x 1.5	10	73	44.5	12	22
	8	7.0	M 20 x 1.5	12	77	46.0	12	22
	10	9.0	M 22 x 1.5	14	84	48.5	14	27
	13	11.5	M 24 x 1.5	16	87	51.5	14	30
	13	11.5	M 30 x 2	20	91	51.5	16	32
	20	18.0	M 36 x 2	25	110	64.5	18	41
	25	22.0	M 42 x 2	30	120	78.0	20	46
32	30.0	M 52 x 2	38	140	92.0	22	60	

2-way high pressure lever operated SAE flanged ball valve

BOOK INDEX

SECTION INDEX

Flanged connections to
SAE J518 / DIN 6162

3000 & 6000 psi rated

use with split flanges on page 2.55

Ball seal is POM, stem seal is NBR

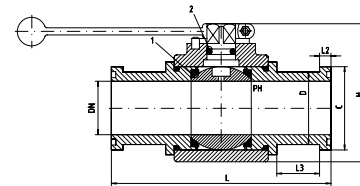

Pressure PB	DN	Approx. Dimensions						Part code
		C	D	H	L	L 2	L 3	
315	13	30.2	24	51.0	151.0	6.7	35	FKH-3000-1/2"-4423
315	20	38.1	32	73.0	162.0	6.7	35	FKH-3000-3/4"-4423
315	24	44.4	38	76.0	178.0	8.0	35	FKH-3000-1"-4423
250	32	50.8	43	105.0	190.5	8.0	35	FKH-3000-1 1/4"-4423
200	38	60.3	50	111.4	231.0	8.0	40	FKH-3000-1 1/2"-4423
200	48	71.4	62	130.0	232.0	9.5	45	FKH-3000-2"-4423
400	13	31.7	24	51.0	151.0	7.7	35	FKH-6000-1/2"-4423
400	20	41.3	32	73.0	174.0	8.8	40	FKH-6000-3/4"-4423
400	24	47.6	38	76.0	198.0	9.5	40	FKH-6000-1"-4423
400	32	54.0	44	105.0	223.0	10.3	45	FKH-6000-1 1/4"-4423
400	38	63.5	51	111.4	281.0	12.6	70	FKH-6000-1 1/2"-4423
400	48	79.4	67	130.0	316.0	12.6	80	FKH-6000-2"-4423

2-way low pressure lever operated ball valve

BOOK INDEX

SECTION INDEX

BSP female thread to ISO 228

Full bore, material AISI 316

Ball and stem seal PTFE
(-20°C to +180°C)

When operating at higher temperatures, please refer to below pressure diagram.

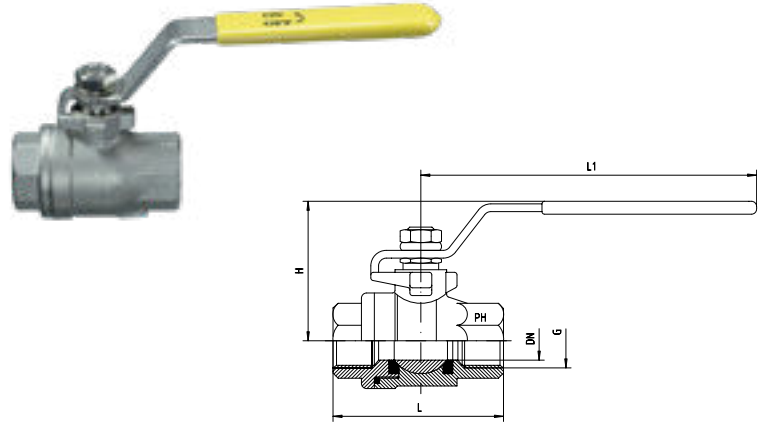

Size	DN	Pressure PB	Approx. Dimensions				Part code
			G	H	L	L1	
1/8"	8.5	63	1/8"	50	55.0	100.0	KH-G 1/8"
1/4"	11.5	63	1/4"	50	55.0	100.0	KH-G 1/4"
3/8"	12.5	63	3/8"	50	55.0	100.0	KH-G 3/8"
1/2"	15.0	63	1/2"	60	65.0	130.0	KH-G 1/2"
3/4"	20.0	63	3/4"	64	72.0	130.0	KH-G 3/4"
1"	25.0	63	1"	71	84.0	165.0	KH-G 1"
1 1/4"	32.0	63	1 1/4"	78	94.0	165.0	KH-G 1 1/4"
1 1/2"	38.0	63	1 1/2"	86	110.0	190.0	KH-G 1 1/2"
2"	50.0	63	2"	95	126.0	190.0	KH-G 2"
2 1/2"	65.0	40	2 1/2"	130	161.0	250.0	KH-G 2 1/2"
3"	80.0	40	3"	148	178.0	250.0	KH-G 3"

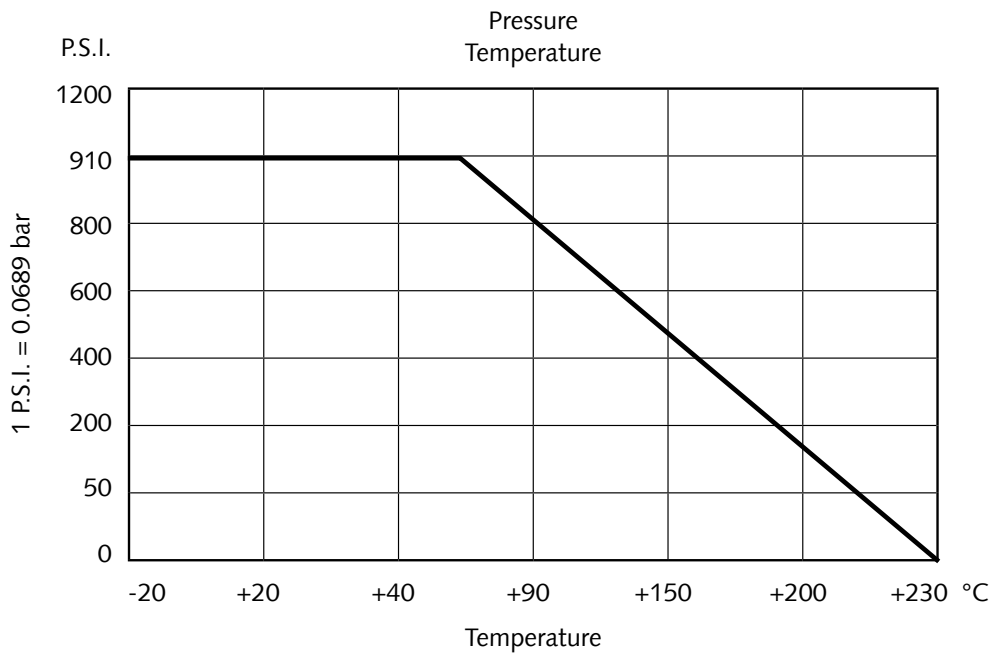

3-way low pressure lever operated ball valve

BOOK INDEX

SECTION INDEX

BSP female thread to ISO 228

L bore, material AISI 316

Ball and stem seal PTFE
(-20°C to +180°C)

When operating at higher temperatures, please refer to below pressure diagram.

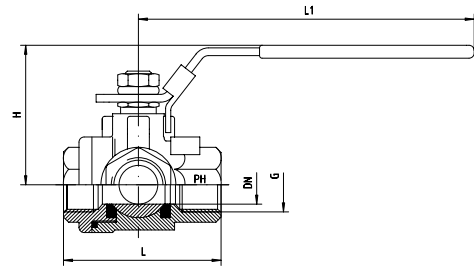

Size	DN	Pressure PB	Approx. Dimensions				Part code
			G	H	L	L1	
1/4"	11.2	63	1/4"	50	68	97	KH-G 1/4"-3-W-L
3/8"	11.2	63	3/8"	50	68	97	KH-G 3/8"-3-W-L
1/2"	12.7	63	1/2"	50	68	97	KH-G 1/2"-3-W-L
3/4"	16.0	63	3/4"	64	83	127	KH-G 3/4"-3-W-L
1"	20.0	63	1"	66	90	127	KH-G 1"-3-W-L
1 1/4"	25.0	63	1 1/4"	80	97	145	KH-G 1 1/4"-3-W-L
1 1/2"	32.0	63	1 1/2"	83	114	145	KH-G 1 1/2"-3-W-L
2"	38.1	63	2"	96	142	205	KH-G 2"-3-W-L

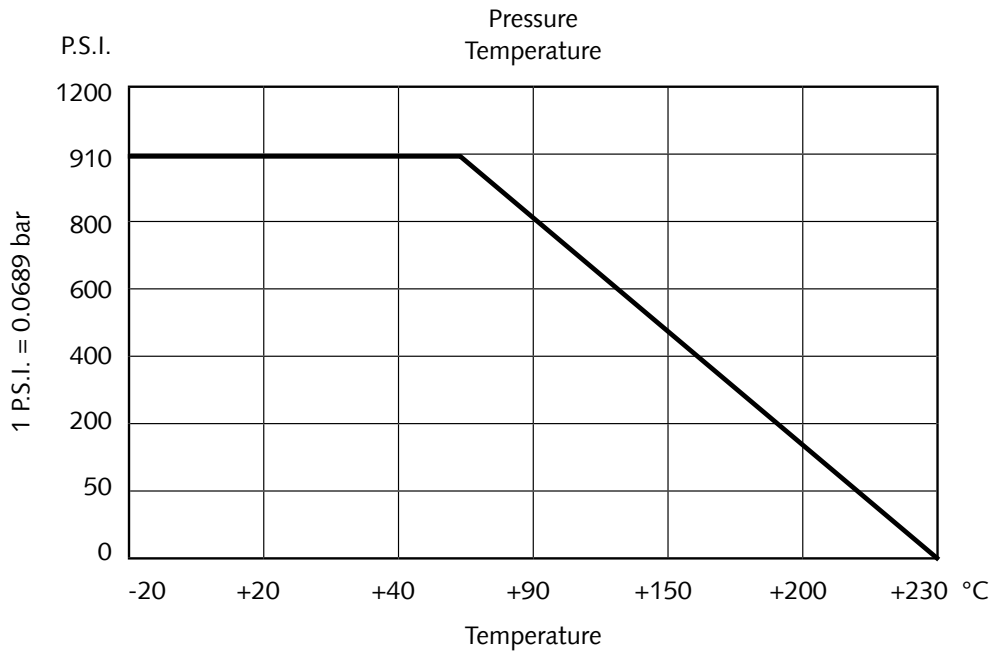

3-way low pressure lever operated ball valve

BOOK INDEX

SECTION INDEX

BSP female thread to ISO 228

T bore, material AISI 316

Ball and stem seal PTFE
(-20°C to +180°C)

When operating at higher temperatures, please refer to below pressure diagram.

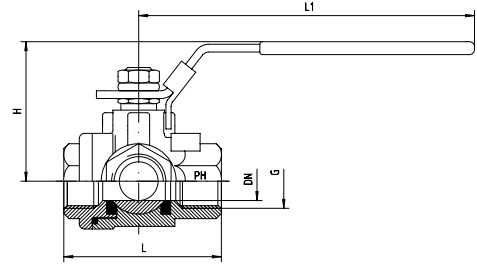

Size	DN	Pressure PB	Approx. Dimensions				Part code
			G	H	L	L1	
1/4"	11.5	63	1/4"	50	68	97	KH-G 1/4"-3-W-T
3/8"	12.5	63	3/8"	50	68	97	KH-G 3/8"-3-W-T
1/2"	12.5	63	1/2"	50	68	97	KH-G 1/2"-3-W-T
3/4"	15.0	63	3/4"	64	83	127	KH-G 3/4"-3-W-T
1"	20.0	63	1"	66	90	127	KH-G 1"-3-W-T
1 1/4"	25.0	63	1 1/4"	80	97	145	KH-G 1 1/4"-3-W-T
1 1/2"	32.0	63	1 1/2"	83	114	145	KH-G 1 1/2"-3-W-T
2"	40.0	63	2"	96	142	205	KH-G 2"-3-W-T

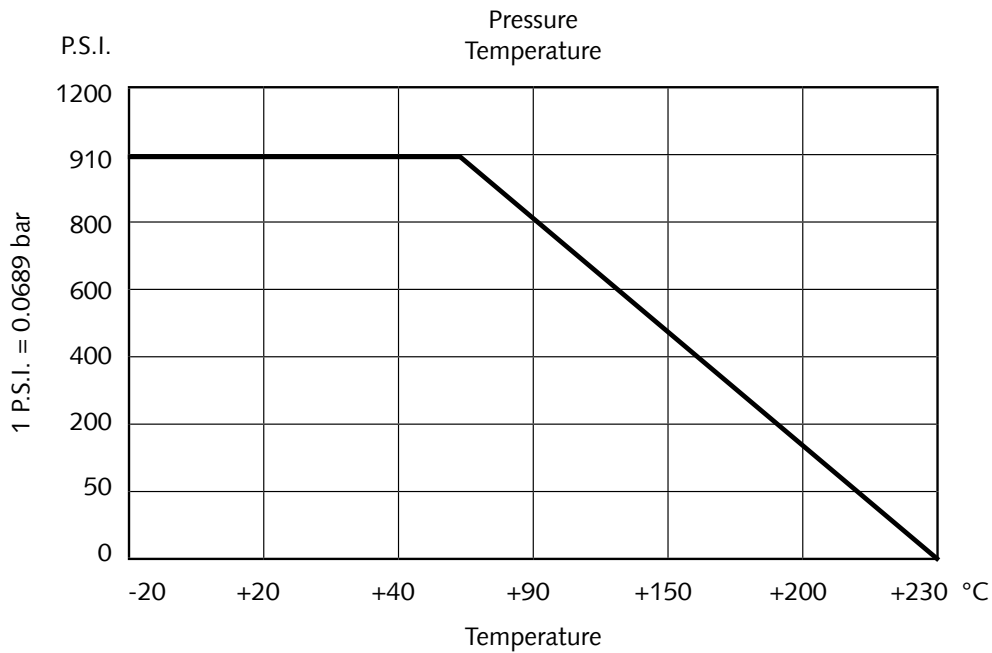

High pressure shut off valve

BOOK INDEX

SECTION INDEX

With externally threaded spindle
compression connection to
ISO 8434-1 / DIN 2353

Note: Adjust the graphite packing
before initial operation.

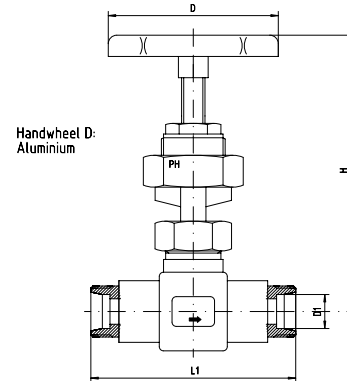

Series	Pressure PB	Tube O.D. D1	Thread G	Approx. Dimensions			Part code OMD
				D	H	L1	
S	400	6	M 14 x 1.5	125	124		HVb-S-06-OMD
S	400	8	M 16 x 1.5	125	124		HVb-S-08-OMD
S	400	10	M 18 x 1.5	125	124	80	HVb-S-10-OMD
S	400	12	M 20 x 1.5	125	124	80	HVb-S-12-OMD
S	400	14	M 22 x 1.5	125	124		HVb-S-14-OMD
S	400	16	M 24 x 1.5	125	124	100	HVb-S-16-OMD
S	400	20	M 30 x 2	125	124	100	HVb-S-20-OMD
S	400	25	M 36 x 2	125	153		HVb-S-25-OMD

Temperature	Required Pressure Reductions				
	50°C	100°C	200°C	300°C	400°C
Pressure Reduction	6%	15%	37%	60%	84%

Intermediate values are to be interpolated.

High pressure shut off valve

BOOK INDEX

SECTION INDEX

With internally threaded spindle
compression connection to
ISO 8434-1 / DIN 2353

Note: Adjust the graphite packing
before initial operation.

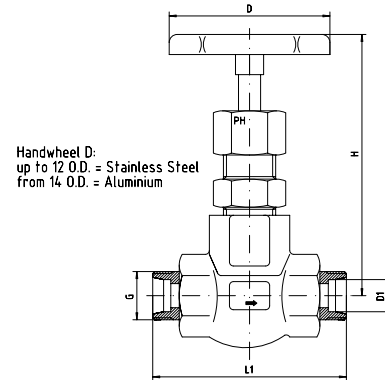

Series	Pressure PB	Tube O.D. D1	Thread G	Approx. Dimensions			Part code OMD
				D	H	L1	
S	630	6	M 14 x 1.5	70	85	65	HVa-S-06-OMD
S	630	8	M 16 x 1.5	70	85	65	HVa-S-08-OMD
S	630	10	M 18 x 1.5	70	85	65	HVa-S-10-OMD
S	630	12	M 20 x 1.5	70	85	65	HVa-S-12-OMD
S	630	14	M 22 x 1.5	125	110	100	HVa-S-14-OMD
S	400	16	M 24 x 1.5	125	125	100	HVa-S-16-OMD
S	400	20	M 30 x 2	125	125	100	HVa-S-20-OMD
S	400	25	M 36 x 2	125	125	100	HVa-S-25-OMD
S	250	30	M 42 x 2				HVa-S-30-OMD
S	250	38	M 52 x 2				HVa-S-38-OMD

Series	Pressure PB	Tube O.D. D1	Thread G	Approx. Dimensions			Part code OMD
				D	H	L1	
L	315	6	M 12 x 1.5	70	85	65	HVa-L-06-OMD
L	315	8	M 14 x 1.5	70	85	65	HVa-L-08-OMD
L	315	10	M 16 x 1.5	70	85	65	HVa-L-10-OMD
L	315	12	M 18 x 1.5	70	85	65	HVa-L-12-OMD
L	315	15	M 22 x 1.5	125	125	100	HVa-L-15-OMD
L	315	18	M 26 x 1.5	125	125	130	HVa-L-18-OMD
L	160	22	M 30 x 2	125	125	130	HVa-L-22-OMD
L	160	28	M 36 x 2	125	125	130	HVa-L-28-OMD
L	160	35	M 45 x 2				HVa-L-35-OMD
L	160	42	M 52 x 2				HVa-L-42-OMD

Required Pressure Reductions					
Temperature	50°C	100°C	200°C	300°C	400°C
Pressure Reduction	6%	15%	37%	60%	84%

Intermediate values are to be interpolated.

Needle valve

BOOK INDEX

SECTION INDEX

with PTFE packing
 BSP female thread to ISO 228
 BSP parallel and NPT female threads
 temperature -20°C to +200°C
Note: Adjust the PTFE packing
 before initial operation

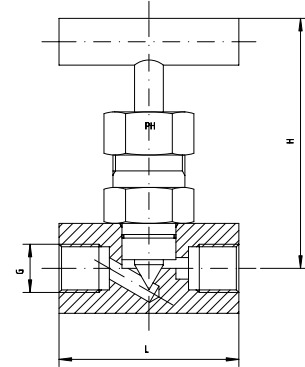

Pressure PN	Thread G	Approx. Dimensions		Part code
		H	L	
420	1/8" zyl	66.0	59.0	NV-G 1/8" -BSP
420	1/4" zyl	66.0	59.0	NV-G 1/4" -BSP
420	3/8" zyl	66.0	59.0	NV-G 3/8" -BSP
420	1/2" zyl	66.0	65.0	NV-G 1/2" -BSP
420	3/4" zyl	94.5	70.0	NV-G 3/4" -BSP
420	1" zyl	94.5	80.0	NV-G 1" -BSP

Pressure PN	Thread G	Approx. Dimensions		Part code
		H	L	
420	1/8" NPT	66.0	59.0	NV-1/8"-NPT
420	1/4" NPT	66.0	59.0	NV-1/4"-NPT
420	3/8" NPT	66.0	59.0	NV-3/8"-NPT
420	1/2" NPT	66.0	65.0	NV-1/2"-NPT
420	3/4" NPT	94.5	70.0	NV-3/4"-NPT
420	1" NPT	94.5	80.0	NV-1"-NPT

Needle valve pressure drop data

BOOK INDEX

SECTION INDEX

